

AX6300S Series

1. Overview

The ALAXALA AX6300S series of multi-layer switches offers the following two models:



AX6304S



AX6308S

1.1 Product concept

The AX6300S series features multi-layer switches that enable "guaranteed networks" as well as the following functionality.

1. Large capacity and compact design

The AX6300S series features entry-class switches that have been made more compact by moving the packet forwarding functionality to the shared section, enabling enterprises to implement many 1-gigabit and 10-gigabit lines. Using the AX6300S series together with the compact AX2400S, AX2500S, or AX3600S series enables a high-performance network at a low cost.

2. High reliability and availability

The AX6300S series contains hardware and software that guarantees high reliability and availability, as already demonstrated in the AX7800R, AX7800S, and AX5400S series. In addition, functionality that improves reliability, such as link aggregation, graceful restart, GSRP, and the Autonomous Extensible Ring Protocol, have been added to the switches to construct highly reliable networks.

3. Operation and management cost reduction

By integrating multiple virtual service networks within one physical network, network partitions can be created to reduce building and operating costs.

4. Environmentally friendly design

The intensive engine system in the AX6300S series reduces the number of ASICs used per switch, thus reducing power consumption for the all switches in a network. The AX6300S series supports a power saving mode in which both normal power consumption mode and switching performance are suppressed.

5. Low cost

The AX6300S series lowers the cost per port by achieving a high port density for both 1-gigabit Ethernet and 10-gigabit Ethernet ports with a maximum switching capacity of 192 Gbit/s.

- 10-gigabit Ethernet: Maximum of 64 ports (AX6308S)
- 1-gigabit Ethernet: Maximum of 192 ports (AX6308S)

6. High level of security

The AX6300S series supports IEEE 802.1X and Web authentication. In combination with MAC VLANs, the AX6300S series also offers highly secure VLANs in dynamically changing environments.

Through MAC-based authentication, users can also authenticate printers and other switches. Unicast Reverse Path Forwarding (uRPF) can prevent unauthorized traffic such as spoofing.

1.2 Usage examples

The AX6300S series features multi-layer, enterprise-oriented gigabit switches, which prioritize the efficient handling of 1-gigabit and 10-gigabit lines, making it possible to achieve a high cost-performance ratio, while also incorporating the reliability and functionality inherit in the carrier-class, large-capacity AX7800S series.

Example of using AX6300S series switches as core switches for a campus network

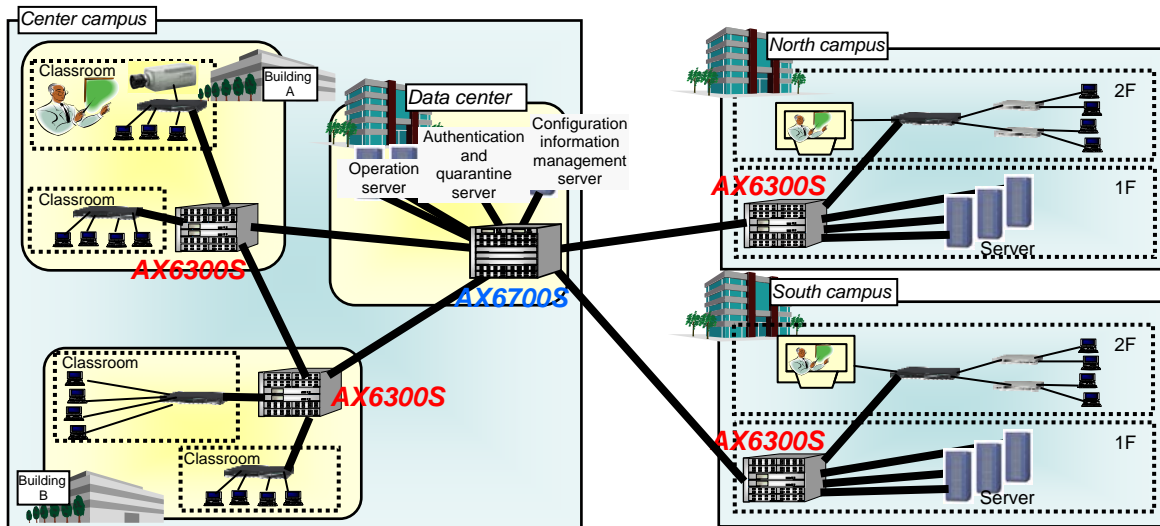

Switch usage		Points
Large-scale independent network	High-reliability Layer 3 switch compatible with Ring Protocol	<ul style="list-style-type: none"> - 10-gigabit dark fiber - Stable operation and rapid switchover if a failure occurs - Quick and reliable switching using the simple Ring Protocol
Enterprise LAN (Campus network)	Core switch	<ul style="list-style-type: none"> - Stable network with enhanced high-availability functionality - Prevention of problems, such as virus infection and information leaks, by using authentication and quarantines - Excellent cost performance, which helps to transition to 10 gigabit - Power saving functionality for public offices
Service provider network	User accommodation Layer 3 switch, FTTH Layer 2 core switch, WAN Ethernet core Layer 2 switch	<ul style="list-style-type: none"> - High-performance 10-gigabit network to handle increases in traffic - Stable operation and rapid switchover if a failure occurs - Detection and prevention of unauthorized traffic - IPv4/IPv6 dual stacking - Low power consumption
Datacenter	External connections	<ul style="list-style-type: none"> - Space saving by packing ports in a small space - Burst data protection - Low power consumption

2. Features

2.1 Features of the AX6300S series

(1) Unified architecture across the series

- An intensive engine system concentrates packet forwarding functionality in the shared section of the switch.
- Unique and cutting-edge ASICs provide large volume hardware packet transfer, equivalent to that of the AX7800S series, and the intensive engine system reduces the number of ASICs required, which ultimately reduces the price of the switch.
- An integrate module (MSU) consisting of switch control units and packet processing units achieves cost-efficient design. Two types of intensive engines with different table sizes are lined up.
- MSU upgrades allow for switch configurations with enhanced performance. This increases divertibility of chassis/network interface functionality (NIF), thus reducing investment cost.

(2) Power saving

- Adopting an intensive engine system reduces the number of ASICs used per switch, which in turn reduces the power consumed by the all switches in a network.
- Both normal power consumption mode and power-saving mode are available. Power-saving mode improves bandwidth aggregation efficiency by allowing the ASICs to be operated at lower operating frequencies. Even in power-saving mode, all functionality except the switching-capacity suppression functionality can be used.

(3) High quality, reliability, and availability

- High-quality devices
 - High reliability through carefully selected parts and strict design and inspection requirements
 - Stable routing guaranteed by inheriting the software for the AX5400S, AX7800S, and AX7800R series, which have a proven track record on carrier networks
- High level of failure tolerance
 - All major components include a failure detection mechanism.
 - Redundancy within switches for power supplies and MSUs
 - Link aggregation across slots allows redundancy of interface parts.
 - Hot standby redundancy is supported for MSUs to minimize downtime during failures.
- Rapid re-routing
 - The hot standby mechanism delivers rapid re-routing for Layers 2 and 3.
(Layer 2: GSRP, Layer 3: GSRP and VRRP)
 - Link aggregation (IEEE 802.3ad) provides link redundancy at the Layer 2 level.
 - By making specified remote routes reachable, static/VRRP polling can provide dynamic re-routing.
 - The implementation of the Autonomous Extensible Ring Protocol supports diverse ring network configurations. With this functionality, rapid and stable hardware-based Layer 2 redundancy is possible.
 - OSPF balances loads by distributing IP-level traffic and avoiding path failures.
- Layer 2 loop avoidance
 - UDLD prevents spanning tree loops and link aggregation frame loss.
 - The Layer 2 loop detection functionality detects improperly connected devices on the network, which helps prevent loops.
- Prevents failure propagation
 - Normal user traffic can be reduced by minimizing broadcast traffic.
(Storm control functionality)
- Rapid rebooting
 - Graceful restarts can be performed, minimizing the time needed to resume communications during a reboot.
- Online maintenance and upgrades
 - Partial reboots allow for uninterrupted user operation whenever a module is added or a configuration is changed.
 - Modules, power supplies, and fans can be added or replaced with the power on, increasing maintainability during operation.

- Boards can be replaced with the power on and without using commands.
- Software can be updated without needing to stop services.

(4) Industry-leading 10-gigabit Ethernet

- High-density 10-gigabit Ethernet
 - 64 10-gigabit Ethernet ports are provided on every switch. (AX6308S model, XFP support module)
- Large number of 1-gigabit Ethernet ports
 - 192 1000BASE-X ports are provided on every switch. (AX6308S model, SFP support model)
 - 192 10BASE-T/100BASE-TX/1000BASE-T ports are provided on every switch. (AX6308S model)

(5) Robust security

- Advanced and precise packet filtering
 - Hardware-based advanced filtering
- Partial and multiple conditions can be specified for Layer 2, 3, and 4 headers.
- User authentication based on IEEE 802.1X, Web authentication, and MAC VLANs (VLAN access is restricted via MAC addresses) allows for highly secure VLANs to exist in an environment like a wireless LAN office, where user needs often change.
- Devices such as printers can be authenticated by using MAC-based authentication.
- uRPF prevents IP address spoofing.
- Unauthorized DHCP servers and terminals with fixed IP addresses are excluded from networks.
 - The AX6300S series provides strong security measures via functionality such as DHCP snooping, which eliminates unauthorized DHCP servers and terminals with fixed IP addresses.

(6) Network partition support

- Horizontal and vertical network integration reduces costs.
 - By using the VRF functionality, which virtually combines logically separated switches into a single switch, networks that were once physically separate entities can exist within one physical network.
 - Networks can be easily constructed and managed by placing Layer 3 switches at a central location and then connecting them to Layer 2 switches at individual offices and sites.

(7) Industry-leading IPv6 performance and functionality

- IPv6 routing that can take advantage of all the bandwidth of 10-gigabit Ethernet lines
- A variety of IPv6 routing protocols (static, RIPng, OSPFv3, BGP4+, policy-based routing, PIM, and MLDv2) allow diverse, flexible IPv6 networks to be built.
- Network management (SNMP over IPv6) and authentication management (RADIUS over IPv6) in IPv6-only environments are supported.
- Detailed conditions other than IPv6 addresses can be used for filtered searches to enhance IPv6 network security.
- IPv6 Ready Logo Ph.2
 - In addition to phase 1 features, phase 2 features are supported, to provide a more practical IPv6 that more strictly conforms to specifications.

(8) Enhanced IPv4 routing protocols supporting a variety of network configurations

- You can choose from a variety of routing protocols according to the network type and size.
 - Static, RIP, OSPF, BGP4, policy routing, PIM-SM/SSM, and IGMPv3
- Policy-based routing
 - Supports policy-based routing in which optimal routes are selected according to the status of a forwarding destination.

(9) Hardware-based, advanced QoS delivered via Ethernet

- Detailed specification of parameters is possible, and precise QoS control prevents congestion of important user communication (packets and frames).
- Extensible QoS for a wide range of applications, from enterprises to carriers
- Multistage shaping functionality for maximum and minimum bandwidth, etc. (provided by the hierarchical shaper NIF).

(10) Excellent support for Layer 2 functionality

- Various VLAN functionalities
 - Equipped with port VLAN, protocol VLAN, and MAC VLAN functionality
 - Flexible VLAN configurations that can be adapted to your requirements
- Spanning Tree Protocol
 - Supports the Spanning Tree Protocol (IEEE 802.1D), the Rapid Spanning Tree Protocol (IEEE 802.1w), PVST+, and Multiple Spanning Tree (IEEE 802.1s)
- Layer 2 - Virtual Private Network (L2-VPN) using VLAN tunneling
- Policy-based switching
 - Supports policy-based switching, in which Layer 2 forwarding is performed for a destination interface specified by users, instead of the routing information registered in the MAC address table.
 - Selects optimal routes according to the status of a forwarding destination.

(11) Compact design

- The power supply is inserted into the rear panel with a low profile, allowing switches to be easily and efficiently placed in racks.

(12) Excellent network management, maintenance, and operation

- CFM (Connectivity Fault Management) (Ether OAM)
 - Connectivity monitoring and failure management are available at the Layer 2 level by performing continuity checks (CC), loopbacks, and linktraces.
- In addition to the basic MIB-II, many other MIBs, including IPv6-MIB and RMON, are supported.
- The port mirroring functionality allows you to monitor and analyze actual user traffic without affecting user communications. Network failures can be isolated. In addition, the sampling mirroring process, which samples target packets, allows you to monitor 1-gigabit and 10-gigabit Ethernet connections using a low-performance, general-purpose computer.
- Statistics can be collected for specific flows/ports and VLANs for any line speed, ranging from 10 Mbit/s to 10 Gbit/s.
- An ALAXALA CLI, which is the same for all AX series products, is used. This helps reduce the costs of training maintenance personnel.

3. Specifications

3.1 Specifications of the AX6300S series of switches

Specifications			AX6304S	AX6308S
Model name			AX6304S (AC power)	AX6308S (AC power)
Maximum switching capacity			96 Gbit/s	192 Gbit/s
Maximum packet processing capability			60 M packets/s	120 M packets/s
Number of slots	Management switching unit (MSU)		2	2
	Network interface functionality (NIF) (Note 1)		4	8
Number of network interfaces	10GBASE-R	XFP (SR/LR/ER/ZR)	32	64
	1000BASE-X	SFP (SX/SX2/LX/BX/LH)	96	192
	10BASE-T/100BASE-TX/1000BASE-T		96	192
Amount of installed memory	Per MSU		1024 MB (Standard: MSU-1A1) 2048 MB (Extended: MSU-1B1)	
Internal flash memory			1024MB (MSU-1A1/MSU-1B1)	
Number of memory card slots			SD card x 1	
Redundancy			Power supply and MSU section	Power supply and MSU section
Power supply requirements	Voltage	Rated input voltage (V)	100 to 120 AC/200 to 240 AC (Note 3)	100 to 120 AC/200 to 240 AC (Note 3)
		Variation range (V) (Note 2)	90 to 132 AC/180 to 264 AC (Note 3)	90 to 132 AC/180 to 264 AC (Note 3)
	Frequency (Hz)		50/60	50/60
	Maximum input current (A) (Note 4)		16 at 100 V AC 8 at 200 V AC	25 at 100 V AC 12.5 at 200 V AC
	Maximum power consumption (W)		1500	2400
Calorific power (kJ/h)			5400	8640
Power saving mode			Static	
Equipment requirements	External dimensions W x D x H (mm) (height [U]) (Note 5)		443 x 544 x 211 (5U)	443 x 544 x 303 (7U)
	Weight (kg) (maximum) (Note 6)		45	64
Environmental requirements	Temperature	Acceptable operating range	0 to 40°C	
		When not operating (not energized)	-10 to 43°C	
		During storage and transportation	-25 to 65°C	
	Relative humidity	Acceptable operating range	10 to 85 percent (non-condensing)	
		When not operating (not energized)	8 to 85 percent (non-condensing)	
		During storage and transportation	5 to 85 percent (non-condensing)	
Suspended particulates		Suspended particulates smaller than approx. 10 microns: 0.15 mg/m ³		
Vibration (m/s ²)		No more than 2.45		
Applicable standards	EMI standard		VCCI Class A	
	Harmonic current emission standard		JIS C61000-3-2	
	EMS standard		JEITA IT-3001	
	Safety standard		UL60950-1 compliant	

Note 1: For a single-size NIF

Note 2: Range in which normal operation is guaranteed

Note 3: Specifications for an input voltage of 200 V AC

Note 4: Value for the entire switch. For one or more power supply units, the power should be evenly divided by the number of units.

Note 5: The width dimension does not include the size of the bracket.

Note 6: Weight (maximum) refers to the weight of each fully equipped model.

3.2 AX6300S series functionality

Category	Functionality		Relevant standards	Notes
LAN	Ethernet	10BASE-T/100BASE-TX/1000BASE-T	IEEE 802.3, IEEE 802.3u, IEEE 802.3ab	(Note 6)
		10BASE-T/100BASE-TX/1000BASE-T (SFP)	IEEE 802.3, IEEE 802.3u, IEEE 802.3ab	
		1000BASE-X (SX/LX)	IEEE 802.3z	
		1000BASE-X (SX2/BX (40 km support version)/LH)	--	
		1000BASE-BX	IEEE 802.3ah	
		10GBASE-R (SR/LR/ER)	IEEE 802.3ae	
		10GBASE-R (ZR)	--	
		Flow control	IEEE 802.3x	
	Link aggregation	IEEE 802.3ad Link aggregation	IEEE 802.3ad	
		LACP	--	
		Restriction of the number of detached ports	--	
		Standby link	--	
		Mixed speeds (change of line speed)	--	
	Jumbo frame		--	
Layer 2 functionality	Transparent bridge		--	
	MAC address learning	Dynamic	IEEE 802.1D, IEEE 802.1Q	
		Static	--	
		Suppression of MAC address learning	--	
		Restriction of MAC address learning	--	
	VLAN	Port VLAN	IEEE 802.1Q, IEEE 802.1u, IEEE 802.1v	
		VLAN tagging	IEEE 802.1Q	
		Default VLAN	--	
		Protocol VLAN	--	
		MAC VLAN	--	
		Discard of undefined frames	--	
		Tag translation	--	
		BPDU forwarding	--	
		EAPOL forwarding	--	
		VLAN debounce	--	
	VLAN tunneling		--	
	Layer 2 relay blocking functionality		--	
	Spanning Tree Protocol	STP	IEEE 802.1D, IEEE 802.1t	(Note 3)
		RSTP	IEEE 802.1w	(Note 3)
		MSTP	IEEE 802.1s	(Note 3)
		PVST+	--	(Note 3)
		Loop guard	--	(Note 3)
		Edge port	--	(Note 3)
		Root guard	--	(Note 3)
		BPDU guard	--	(Note 3)
	Autonomous Extensible Ring Protocol		--	
	Policy-based switching		--	(Note 9)
		Tracking functionality	--	(Note 9) [NEW]
	DHCP snooping		RFC 2131	
	IGMP / MLD snooping	IGMPv2 snooping	RFC 4541	
		IGMPv3 snooping		
		IGMP snooping instant leave		
		MLDv1 snooping		
MLDv2 snooping				
Storm control		--		
IEEE 802.3ah/UDLD		IEEE 802.3ah		
L2 loop detection		--		
CFM (Connectivity Fault Management) (Ether OAM)		IEEE 802.1ag		
Flush request frame (VRRP) receiving functionality		--		
Flush control frame (uplink redundancy) receiving functionality		--	(Note 5)	

Category	Functionality	Relevant standards	Notes		
Layer 3 functionality	IPv4	IP, ARP, ICMP	RFC 791, RFC 792, RFC 826, RFC 922, RFC 950, RFC 1027, RFC 1122, RFC 1519, RFC 1812, RFC 2644		
		RIP, RIP2	RFC 1058, RFC 1519 RFC 2453		
		VRF-enabled	--	(Note 4)	
		RIPv2 authentication	RFC 4822		
		OSPF	RFC 1519, RFC 2328, RFC 3101, RFC 5309		
			Stub router	RFC 3137	
			VRF-enabled	--	(Note 4)
		Static routing	--		
			VRF-enabled	--	(Note 4)
		Load balancing	--		
	Local Proxy ARP	--			
	IPv6	IPv6, NDP, ICMPv6	RFC 2373, RFC 2460, RFC 2461, RFC 2462, RFC 2463, RFC 2710, RFC 5095		
		RIPng	RFC 2080		
		VRF-enabled	--	(Note 4)	
		OSPFv3	RFC 2740, RFC 5309		
			Stub router	RFC 3137	
		VRF-enabled	--	(Note 4)	
		Static routing	--		
			VRF-enabled	--	(Note 4)
		BGP4/BGP4+	EBGP, IBGP peering	RFC 1519, RFC 1771, RFC 2385, RFC 2842, RFC 2858, RFC 2918, RFC 3392, RFC 4271, RFC 4760, RFC 5492, draft-ietf-idr-avoid-transition-04.txt	(Note 1)
			Community	RFC 1997	(Note 1)
	Route reflection		RFC 2796, RFC 4456	(Note 1)	
	Confederation		RFC 1965, RFC 3065 RFC 5065	(Note 1)	
	Route flap dampening		RFC 2545	(Note 1)	
	BGP maximum prefix		--	(Note 1)	
	VRF-enabled		--	(Note 1) (Note 4)	
	IPv4 multicasts		IGMP ver2	RFC 2236	
		IGMP ver3	RFC 3376		
		Static group join (static)	--		
		VRF-enabled (IGMPv2, v3, static)	--	(Note 4)	
		PIM-SM/-SSM	RFC 2362 draft-ietf-pim-sm-v2-new-05.txt	Only conforming to PIM-SSM-related definitions.	
			RFC 4601 draft-ietf-pim-sm-bsr-07.txt	Only conforming to generation ID-related definitions of the PIM-Hello option.	
BSR extended functionality			--	(Note 8)	
VRF-enabled			--	(Note 4)	
PIM-DM		draft-ietf-pim-v2-dm-03.txt			
IPv6 multicasts		MLD ver1	RFC 2710		
	MLD ver2	RFC 3810			
	Static group join (static)	--			
	VRF-enabled (MLDv1, v2, static)	--	(Note 4)		

Category	Functionality	Relevant standards	Notes		
	PIM-SM/-SSM	RFC 2362			
		draft-ietf-pim-sm-v2-new-03.txt	Only conforming to IPv6-related definitions		
		draft-ietf-pim-sm-v2-new-05.txt	Only conforming to PIM-SSM-related definitions.		
		RFC 4601 draft-ietf-pim-sm-bsr-07.txt	Only conforming to Generation ID-related definitions of the PIM-Hello option.		
		VRF-enabled	--	(Note 4)	
	IPv4 DHCP relay agent		RFC 1542, RFC 1812, RFC 2131		
		VRF-enabled	--	(Note 4)	
	IPv6 DHCP relay		RFC 3315	(Note 7)	
	IPv4 DHCP server		RFC 2131, RFC 2132, RFC 2136, RFC 3679		
	IPv6 DHCP server (prefix delegation)		RFC 3315, RFC 3319, RFC 3633, RFC 3646, RFC 3736, RFC 4075		
	Graceful restart	OSPF, OSPFv3	RFC 2370, RFC 3623, draft-kompella-ospf-opaquev2-00.txt, draft-ietf-ospf-ospfv3-graceful-restart-04.txt		
			VRF-enabled	-- (Note 4)	
		BGP4, BGP4+	draft-ietf-idr-restart-13.txt	(Note 1)	
		VRF-enabled	--	(Note 4)	
	Multipathing (load balancing)	IPv4	--		
			VRF-enabled	-- (Note 4)	
		IPv6	--		
		VRF-enabled	--	(Note 4)	
	Policy-based routing	IPv4	--		
			Policy-based routing group	--	
			Tracking functionality	--	
		VRF-enabled	-- (Note 4)		
		IPv6	--		
	VRF-enabled	--	(Note 4)		
Additional functionality	Flow detection conditions	Layer 2 conditions	--		
		Layer 3 conditions	--		
		Layer 4 conditions	--		
	Filtering		--		
	Access list logging		--		
	QoS/ Diff-Serv	Contract bandwidth monitoring (UPC)		--	
		DSCP marking		RFC 2474, RFC 2475, RFC 2597, RFC 3246, RFC 3260	Only possible on Layer 3 relay packets
		DSCP mapping		--	
		Output priority control		RFC 2597, RFC 3246, RFC 3260	Controllable with 8 queues.
		Tail drop		--	
		Legacy shaper functionality	Port bandwidth control		--
			8PQ		--
			8RR		--
4PQ + 4WFQ			--		
2PQ + 4WFQ + 2BEQ			--		
4WFQ + 4BEQ			--		
	Specification of number of queues		--		

Category	Functionality		Relevant standards	Notes	
	Layer 2 authentication	IEEE 802.1X	Port-based authentication (static)	IEEE 802.1X, RFC 2865, RFC 2866, RFC 2868, RFC 2869, RFC 3162, RFC 3579, RFC 3580, RFC 3748	(Note 3)
			VLAN-based authentication (static)		
			VLAN-based authentication (dynamic)		
			Authenticator		
			Connection to a RADIUS server		
	Web authentication		Fixed VLAN mode	--	(Note 2) (Note 3)
			Keep Alive functionality	--	
			Dynamic VLAN mode	--	(Note 2) (Note 3)
			URL redirection	--	
	MAC-based authentication		Fixed VLAN mode	--	(Note 3)
Dynamic VLAN mode			--	(Note 3)	
Port mirroring			--		
uRPF			RFC 3704		
		VRF-enabled	--	(Note 4)	
Network functionality	Network partitions		--	(Note 4)	
Reliability	Environmental monitoring		--		
	Self-diagnosis (MD)		--		
	Redundant configuration	Power supply	--		
		Management switching unit (MSU)	--		
	Non-stop communication (instantaneous interruption)		--	MSU redundancy	
	Hot standby (VRRP)	IPv4		RFC 3768, draft-ietf-vrrp-unified-spec-02.txt	
			VRF-enabled	--	(Note 4)
			Group switchover functionality	--	
			Rapid switching functionality	--	
		IPv6		draft-ietf-vrrp-ipv6-spec-02.txt, draft-ietf-vrrp-ipv6-spec-07.txt, draft-ietf-vrrp-unified-spec-02.txt	
			VRF-enabled	--	(Note 4)
			Group switchover functionality	--	
			Rapid switching functionality	--	
	Tracking functionality		VRRP polling	--	
Failure monitoring (VLAN interface)			--		
Failure monitoring (Ethernet interface)			--		
Failure monitoring (Port channel interface)			--		
Redundancy switchover functionality on switch (GSRP)	Layer 2		--		
	Layer 3		--		
	VLAN group-only control functionality		--		
	GSRP aware		--		

Category	Functionality	Relevant standards	Notes	
Network management	SNMP (v1/v2c/v3)	RFC 1155, RFC 1157, RFC 1901, RFC 1902, RFC 1903, RFC 1904, RFC 1905, RFC 1906, RFC 1907, RFC 1908, RFC 2578, RFC 2579, RFC 2580, RFC 3410, RFC 3411, RFC 3412, RFC 3413, RFC 3414, RFC 3415, RFC 3416, RFC 3417, RFC 3418, RFC 3584		
	VRF-enabled	--	(Note 4)	
	MIB-II, RMON, IP Forwarding MIB, Interface MIB	RFC 1158, RFC 1213, RFC 1354, RFC 1757, RFC 2233		
	IPv6 MIB	RFC 2452, RFC 2454, RFC 2465, RFC 2466		
	Private MIB	Statistics	--	
		L2 (VLAN, FDB, GSRP)-related	--	
		Neighborhood information (LLDP, OADP)-related	--	
		Filter/QoS-related	--	
		Various protocols (OSPF, etc.)-related	--	
		System information (Boot information, login)	--	
		Switch information	--	
		Power consumption information	--	
	sFlow-related	--		
	VRF-related	--	(Note 4)	
	IPv4 PIM MIB	RFC 2934		
	dot1dBridge MIB	RFC 1493, RFC 2674		
	Ethernet MIB	RFC 1643		
	MIBs for various protocols (OSPF, BGP, etc.)	RFC 1657, RFC 1850, draft-ietf-ospf-ospfv3-mib-03.txt		
	VRRP MIB	IPv4	RFC 2787	
		IPv6	draft-ietf-vrrp-unified-mib-04.txt	
	IEEE 802.3ad MIB	IEEE 802.3ad		
	snmpModules MIB	RFC 3411, RFC 3412, RFC 3413, RFC 3414, RFC 3415		
	CFM-MIB	IEEE 802.1ag		
	LLDP	IEEE 802.1AB/D6.0		
	OADP (Octpower Auto Discovery Protocol)	--		
	CDP (Cisco Discovery Protocol)	--	Receive only	
	Network management equipment	Management with JP1/Cm2 (OpenView-based)	--	
		NEC WebSAM Netvisor	--	
		Third-party vendors	--	
	Flow statistics	Flow statistics for filters and QoS	--	
		sFlow statistics	RFC 3176	
	Statistical information on a line-by-line basis	--		
VLAN statistics	--			
Statistics per logical interface	--			
Statistics per queue	--			
Operation and maintenance	Connection with operation terminals	Serial (console)	--	
		Serial (AUX)	--	
		Communication ports (NIF)	--	
		Management ports (IPv4)	--	
	Management ports (IPv6)	--		
Configuration	CLI	--		

Category	Functionality	Relevant standards	Notes	
	Security	Login authentication (password, host address, RADIUS, TACACS+)	RFC 2865, RFC 2866, RFC 3162, draft-grant-tacacs-02-txt	
		SSH (Ver1/Ver2)	draft-ietf-secsh-architecture-12.txt, draft-ietf-secsh-connect-15.txt, draft-ietf-secsh-dh-group-exchange-02.txt, draft-ietf-secsh-transport-14.txt, draft-ietf-secsh-publickeyfile-03.txt, draft-ietf-secsh-userauth-15.txt, draft-ytonen-ssh-protocol-00.txt	
		DoS attack protection	--	
		Replacement/addition of boards while online	--	
	Collection of management information	Display of switch/interface status	--	
		Statistics	--	
		Statistical information on a line-by-line basis	--	
	System status display	SOP (System Operation Panel)	--	
		Status LED (on each board)	--	
		Lamp test functionality	--	
	NTP	VRF-enabled (IPv4 only)	RFC 1305	(Note 4)
		Command-free maintenance functionality	--	
		Software update without interrupting communication	--	
	Power saving	Static power saving only	--	
		Power consumption information indication	--	
Log information	syslog	RFC 3164		
	VRF-enabled	--	(Note 4)	
	Email notification (logger email)	--		

Note 1: An optional license (OP-BGP) is required.

Note 2: Encrypted communication using Secure Socket Layer (SSL) is also available.

Note 3: This functionality cannot be used in combination with VRF.

Note 4: An optional license (OP-NPAR) is required.

Note 5: Uplink redundancy is supported in the AX1240S, AX1250S, AX2400S, AX2500S, AX3600S, and AX3800S series.

Note 6: Only supported by the NH1G-24S.

Note 7: An optional license (OP-DH6R) is required.

Note 8: An optional license (OP-MBSE) is required.

Note 9: MSU-1B1 must be installed.

4. Ordering Information

4.1 AX6300S series

No.	Model name	Abbreviated name	Basic specifications
LAN Switch			
1	AX-6300-S04X	AX6304S	Four-slot chassis for AX6304S (AC) <Includes the following products> <ul style="list-style-type: none"> - Two blank panels (BPNL-PS11) for the AC power supply units - One blank panel (BPNL-SU11) for the MSU, CSU, and BSU of the AX6300S, AX6600S, and AX6700S series - Three blank panels (BPNL-NF11) for single-size NIFs and AX6708S BCUs - Two fan units for the AX6300S, AX6600S, and AX6700S series
2	AX-6300-S08X	AX6308S	Eight-slot chassis for AX6308S (AC) <Includes the following products> <ul style="list-style-type: none"> - Four blank panels (BPNL-PS11) for the AC power supply units - One blank panel (BPNL-SU11) for MSU, CSU, and BSU of the AX6300S, AX6600S, and AX6700S series - Seven blank panels (BPNL-NF11) for single-size NIFs and AX6708S BCUs - Three fan units for the AX6300S, AX6600S, and AX6700S series
Basic Control Section			
1	AX-F6300-51A1X	MSU-1A1	Standard management switching unit for AX6304S and AX6308S (large-capacity version with built-in flash memory) <ul style="list-style-type: none"> - MAC entries = 48 K, IPv4 unicast entries = 64 K, Amount of memory = 1024 MB
2	AX-F6300-51B1X	MSU-1B1	Extended management switching unit for AX6304S and AX6308S (large-capacity version with built-in flash memory) <ul style="list-style-type: none"> - MAC entries = 120 K, IPv4 unicast entries = 208 K, Amount of memory = 2048 MB
Power Supply Unit			
1	AX-F6300-1A11X	PS-A11	AC power supply unit for the AX6300S, AX6600S, and AX6700S series (100/200 V AC)
Common Options			
1	AX-F0110-SD1GX	SD1G	1 GB SD memory card (Note 4)
2	AX-F6300-CBR11X	BRK-11	Rack mounting bracket for AX6304S and AX6604S (Note 1)
3	AX-F6300-CBR12X	BRK-12	Rack mounting bracket for AX6308S and AX6608S (Note 1)
4	AX-F6300-CBR14X	BRK-14	Support bracket for AX6304S and AX6604S (Note 2)
Network Interface Unit			
1	AX-F6300-713TX	NH1G-24T	For the AX6300S series Ethernet LAN with 24 ports for 10BASE-T/100BASE-TX/1000BASE-T <ul style="list-style-type: none"> - RJ-45 interface - Single size - Equipped with shaper functionality - Equipped with priority control functionality - Supports power saving mode Supported in Ver.10.3 and later.
2	AX-F6300-713SX	NH1G-24S	For the AX6300S series Ethernet LAN with 24 ports for 1000BASE-X (SX/SX2/LX/BX/LH) <ul style="list-style-type: none"> - SFP required separately - Single size - Equipped with shaper functionality - Equipped with priority control functionality - Supports power saving mode - SFP-T can be installed Supported in Ver.10.3 and later.
3	AX-F6300-722FX	NH10G-4RX	For the AX6300S series Ethernet LAN with 4 ports for 10GBASE-R (SR/LR/ER/ZR) <ul style="list-style-type: none"> - XFP required separately - Single size - Equipped with the shaper functionality - Equipped with priority control functionality - Supports power saving mode Supported in Ver.10.3 and later.

No.	Model name	Abbreviated name	Basic specifications
4	AX-F6300-723FX	NH10G-8RX	For the AX6300S series Ethernet LAN with 8 ports for 10GBASE-R (SR/LR/ER/ZR) - XFP required separately - Single size - Equipped with the shaper functionality - Equipped with priority control functionality - Supports power saving mode Supported in Ver.10.3 and later.
Optical Transceiver			
1	AX-F6244-3S1TX	SFP-T	SFP for 10BASE-T/100BASE-TX/1000BASE-T Supported in Ver. 11.1.C and later
2	AX-F6244-3S1SX	SFP-SX	SFP for 1000BASE-SX (MMF: 2 m to 550 m)
3	AX-F6244-3S1S2X	SFP-SX2	SFP for 1000BASE-SX2 (MMF: 2 m to 2 km) Supported in Ver. 10.5 and later
4	AX-F6244-3S1LX	SFP-LX	SFP for 1000BASE-LX (MMF: 2 m to 550 m) (SMF: 2 m to 5 km)
5	AX-F6244-3SB1UX	SFP-BX1U	SFP for 1000BASE-BX10-U (SMF: 0.5 m to 10 km) Supported in Ver. 10.5 and later
6	AX-F6244-3SB1DX	SFP-BX1D	SFP for 1000BASE-BX10-D (SMF:0.5 m to 10 km) Supported in Ver. 10.5 and later
7	AX-F6244-3SB4UX	SFP-BX4U	SFP for 1000BASE-BX40-U (SMF: 0.5 m to 40 km) Supported in Ver. 10.5 and later
8	AX-F6244-3SB4DX	SFP-BX4D	SFP for 1000BASE-BX40-D (SMF: 0.5 m to 40 km) Supported in Ver. 10.5 and later
9	AX-F6244-3S1LHX	SFP-LH	SFP for 1000BASE-LH (SMF: 2 m to 70 km)
10	AX-F6244-3X1SX	XFP-SR	XFP for 10GBASE-SR (MMF: 2 m to 300 m)
11	AX-F6244-3X1LX	XFP-LR	XFP for 10GBASE-LR (SMF: 2 m to 10 km)
12	AX-F6244-3X1EX	XFP-ER	XFP for 10GBASE-ER (SMF: 2 m to 40 km)
13	AX-F6244-3X1ZX	XFP-ZR	XFP for 10GBASE-ZR (SMF: 2 m to 80 km) Supported in Ver. 10.6 and later
Components for Maintenance and Configuration Changes			
1	AX-F6300-CPS11X	BPNL-PS11	Blank panel for power supply units, required for empty slots
2	AX-F6300-CSU11X	BPNL-SU11	Blank panel for the MSU/CSU/BSU of the AX6300S, AX6600S, and AX6700S series, required for empty slots
3	AX-F6300-CNF11X	BPNL-NF11	Blank panel for single-size NIFs and AX6708S BCU, required for empty slots
4	AX-F6300-CFAN11X	FAN-11	Fan unit for the AX6300S, AX6600S, and AX6700S series
Software			
1	AX-P6300-S1X	OS-S	Basic software for the AX6300S, AX6600S, and AX6700S series (without SSH support) (VLAN, STP, GSRP, IP packet forwarding, static routing, RIP, RIPng, OSPF, OSPFv3, IPv4 multicasting, IPv6 multicasting, SNMPv3, and HTTP)
2	AX-P6300-S2X	OS-SE	Basic software for the AX6300S, AX6600S, and AX6700S series (with SSH support) (VLAN, STP, GSRP, IP packet forwarding, static routing, RIP, RIPng, OSPF, OSPFv3, IPv4 multicasting, IPv6 multicasting, SNMPv3, HTTP, SSH, and HTTPS)
3	AX-P6300-F1X	OP-BGP	BGP4, BGP4+ license for the AX6300S, AX6600S, and AX6700S series
4	AX-P6300-F3X	OP-NPAR	Network partition license for the AX6300S, AX6600S, and AX6700S series Supported in Ver. 11.0 and later (Note 3)
5	AX-P6300-F4X	OP-MBSE	IPv4 multicasting BSR extended functionality license for the AX6300S, AX6600S, and AX6700S series Supported in Ver. 11.4.C and later
6	AX-P6300-F9X	OP-DH6R	IPv6 DHCP relay functionality license for the AX6300S, AX6600S, and AX6700S series Supported in Ver. 11.4 and later

Note 1: The hardware included in the switch chassis uses flat screws to secure the switch front to the rack column. This bracket is required when you want to place the switch 50 mm back from the rack columns.

Note 2: This bracket does not require guide rails. It can be used in combination with BRK-11.

Note 3: MSU-1B1 must be installed.

Note 4: The software and script are not installed when shipped from the factory.

[Copyright]

All Rights Reserved, Copyright (C), 2006, 2012 ALAXALA Networks, Corp.

[Edition History]

September 2012 (Ver. 11.9: Edition 1)

Note 1: SSH functionality is subject to export control regulations, and might be unavailable for use with exported products.

Note 2: The company names, product names, and names of company-specific features that are included in this document are the registered trademarks or trademarks of their respective owners.

Note 3: Product appearance and specifications are subject to change without notice.

Note 4: In the event that any or all ALAXALA products (including technologies, programs and services) described or contained herein are controlled under any of applicable export control laws and regulations (including the Foreign Exchange and Foreign Trade Law of Japan and United States export control laws and regulations), such products shall not be exported without obtaining the required export licenses from the authorities concerned in accordance with the above laws.



ALAXALA Networks Corporation
URL: <http://www.alaxala.com/en/>
ShinKawasaki Mitsui Bldg West Tower,
1-1-2 Kashimada,
Saiwai-ku, Kawasaki-shi, Kanagawa 212-0058
Japan
Contact URL:
<http://www.alaxala.com/en/contact/>

Contact:

--